



INSTALLATION AND MAINTENANCE INSTRUCTIONS

WALDIS SAFES

RESISTANCE LEVEL VII CD

AS PER EN1143-1



Thank you

Thank you so much for putting your trust in Waldis for your security needs.

You've chosen to buy an EN1143-1-certified safe. A high-quality Swiss product checked and approved by the VdS.

Please read these instructions carefully before setting up your safe!

For any questions, please contact:

WALDIS Tresore AG

Hofwissenstrasse 20

CH-8153 Rümlang

Tel: +41 43 211 12 00

Fax: +41 43 211 12 12

Email: info@tresore.ch

Contents

1. General information	1
1.1. Safety instructions	1
1.2. Table of weights.....	1
1.3. Regulations and insurance	2
1.4. operating elements.....	2
1.5. Set-up.....	2
2. Installation.....	3
2.1. Positioning against the building wall	3
2.2. Disassembly, interior construction	4
2.3. Assembly, interior construction	6
2.4. Cable entry / power connection	8
2.5. USB-Hub.....	9
3. Maintenance and care instructions	9
4. Exemption from liability	10
5. Guarantee against theft	10

1. General information

Every WALDIS Ultra safe is equipped with an electronic security lock. To operate the lock, please use the 500.0024 / 500.0026 instruction manuals enclosed. You can find the comprehensive OM_PAXOS_V004_20181221_EN instruction manual, produced by the manufacturer, at: www.domakaba.com.

1.1. Safety instructions



PLEASE NOTE: This appliance can be used by children aged from 8 years and above and persons with reduced physical, sensory or mental capabilities or lack of experience if they have been given supervision or instruction concerning use of the appliance in a safe way and understand the hazards involved. Children must be supervised and should not play with the appliance. Cleaning and user maintenance must not be carried out by children unless they are over 8 years of age and are supervised.



PLEASE NOTE: Please make sure that no body parts get trapped between the doors and the case when opening and closing the doors!

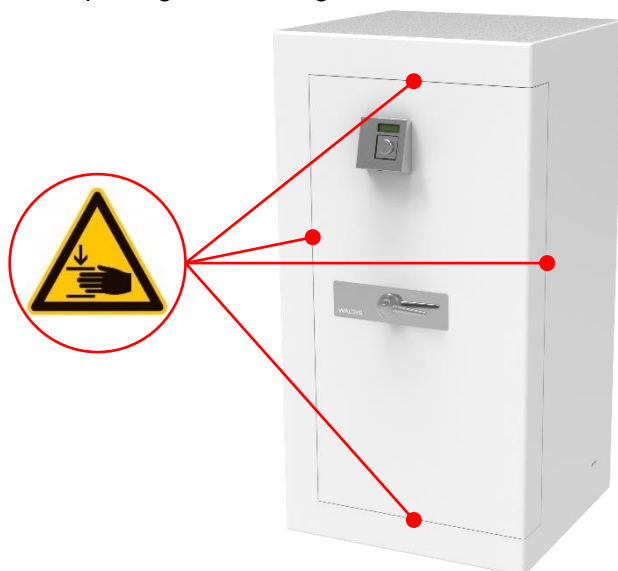

PLEASE NOTE: Before closing the doors, make sure that the handle is in the open position and the bolt is retracted!

1.2. Table of weights

To transport and move the safe, please consult the following table for the weights of the different models:

Model	Weight (kg)
Ultra 1200	1620
Ultra 1500	1970
Ultra 1800	2330
Ultra 1500-XL	2550

1.3. Regulations and insurance

As all sizes in the WALDIS Ultra series exceed the minimum weight for anchoring (1000 kg) according to the EN1143-1 standard, it is not necessary to anchor the safes. Nevertheless, each safe is equipped with 8 holes (4 on the back wall and 4 on the base), diameter 14.5 mm. The holes are used exclusively for transport and load securing and are not certified anchoring holes.



PLEASE NOTE: The safe's warranty and certification terminate after attempted break-ins, fires and unauthorised interference with the structure!

1.4. operating elements

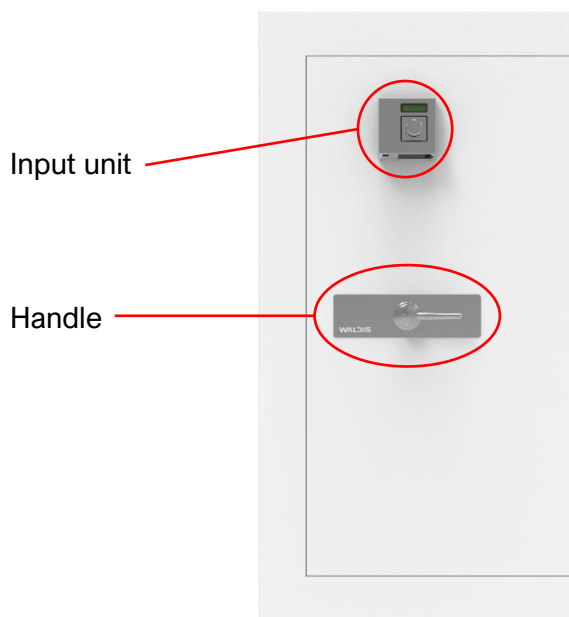

PLEASE NOTE: The following instruction manual explains how to operate a safe with the hinge on the right-hand side of the door! If you have a safe with the hinge on the left-hand side of the door, all rotation, opening and closing movements must go in the opposite direction!

1.5. Set-up

The safe is delivered without a battery inserted as standard, meaning it can be opened and closed without entering a code.

If the battery is inserted and the safe is locked when delivered, please follow the 500.0026 instruction manual.

2. Installation

2.1. Positioning against the building wall

When positioning the safe, please observe the minimum distance (A) from the wall in order to be able to open the door more than 90°. If you want to be able to use the safe's full internal diameter, you also need to observe the minimum distance (B) from the strip side to the wall so that the door can be opened to 115°. If the door needs to be opened 180°, observe the minimum distance (C) from the strip side.

You can find the minimum distances to observe for your model in the table below.

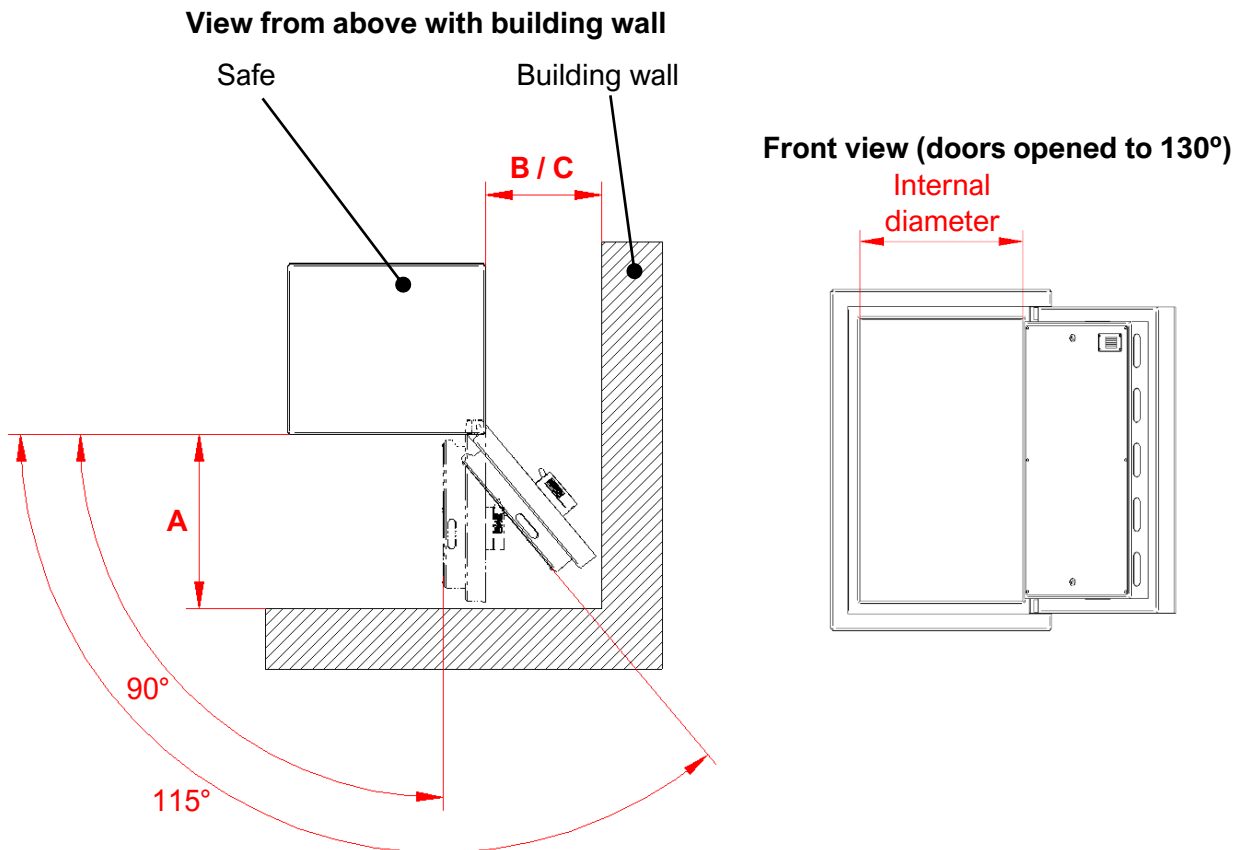

Modell	A für 90° (mm)	B für 115°(mm)	C für 180° (mm)
1200-1800	620	280	620
1500-XL	780	380	780

2.2. Disassembly, interior construction



CAUTION: CUTTING DANGER ON THE METAL SHEETS!

Follow this procedure to disassemble the safe:

1. Open the safe as per the 500.0024 / 500.0026 instruction manual.
2. Pivot the doors as much as possible (ideally 180°).
3. Release the countersunk screw in the lid (3mm Allen key) and push the clamping plate backwards. Then, tighten the countersunk screw again so that the clamping plate cannot slide forward anymore.

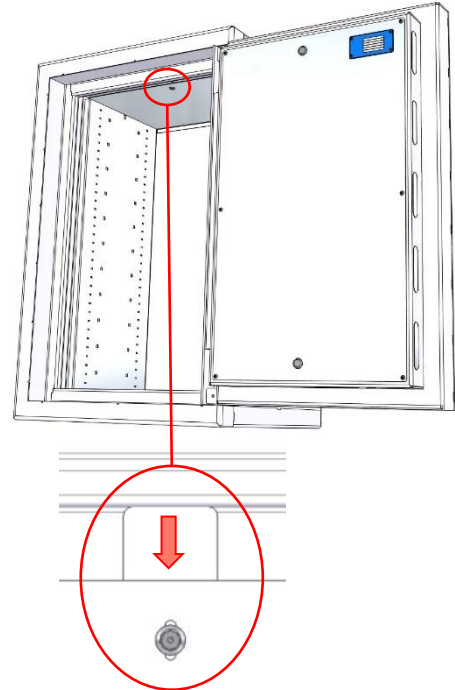

4. Raise the lid slightly and push it to the right until the tabs of the lid can be swivelled past the left-hand side wall. Once the lid has been swivelled approx. 45°, the tabs can be unhooked on the right-hand side wall, and the lid can be pulled out of the safe diagonally.

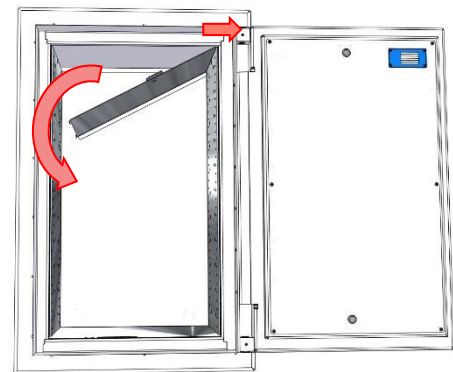

5. Completely unscrew the cylinder-head screw located at the top-centre of the side wall (4mm Allen key), holding the side wall in place with your hand to prevent it from tipping over. Then, allow the side wall to tilt inwards and pull it out of the plug connection in the base. As soon as the side wall is separated from the base, it can be pulled out of the safe diagonally.

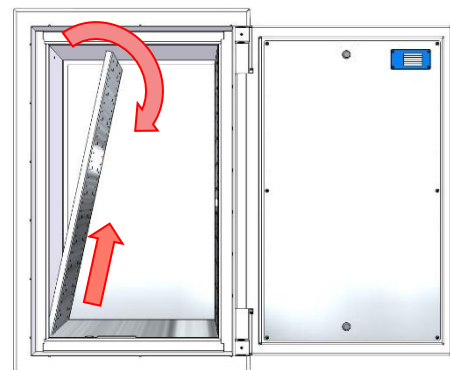

6. Repeat Step 5 for the right-hand side wall.

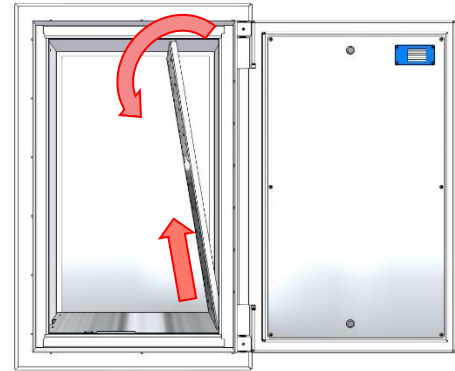

7. Lift the base slightly and then pull it out of the safe diagonally. **Make sure to hold the rear wall in place with your hand!**

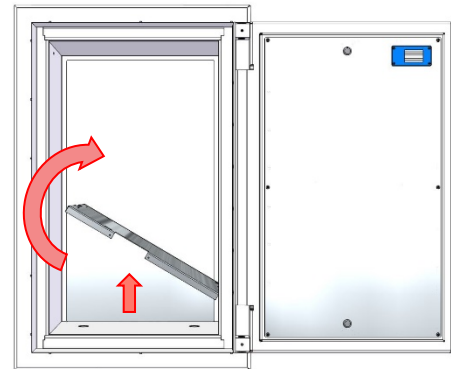

8. Allow the rear wall to tilt forwards from the top and then turn it diagonally forwards onto one side. Then, carefully lift the rear wall and pull it out of the safe.

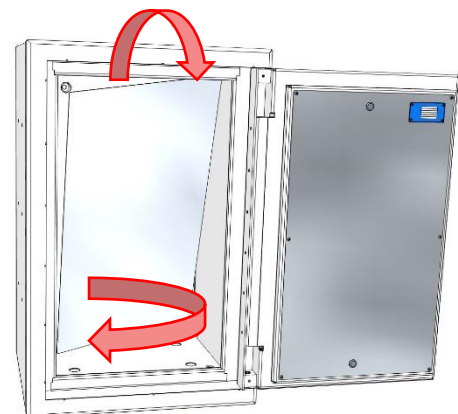

9. Set the disassembled interior construction to one side so that it does not get in the way of anchoring the safe and cannot be damaged.

2.3. Assembly, interior construction



CAUTION: CUTTING DANGER ON THE METAL SHEETS!

1. Allow the rear wall to tilt forwards from the top and then turn it diagonally onto one side. Then, lift the rear wall and carefully push it into the safe. Push the rear wall evenly backwards towards the interior rear wall of the safe.

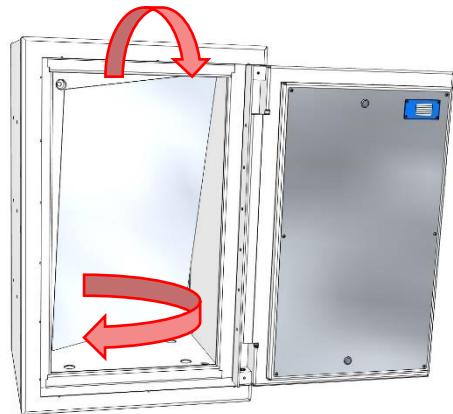

2. Push the base into the safe diagonally and carefully set it down on the interior floor while holding back the rear wall.
Caution: Make sure that no wires get caught when setting the base down!

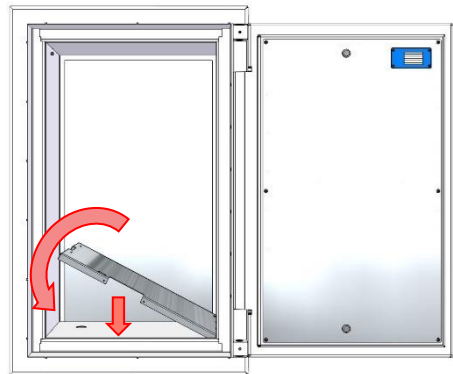

3. Guide the right-hand side wall into the safe diagonally and plug it into the plug connection in the base. As soon as the side wall is plugged into the base, it can be stood upright on the right-hand side and screwed in (4mm Allen key) at the centre of the safe using the cylinder screw.
Caution: Only screw in lightly!

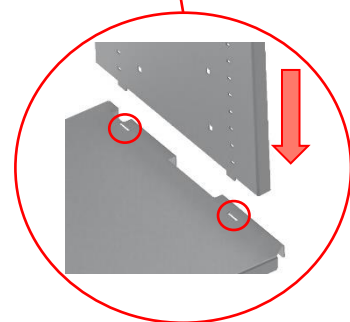
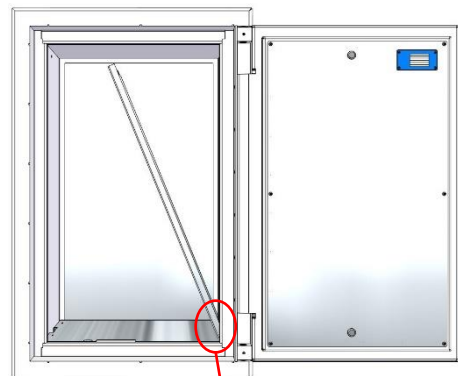

4. Guide the left-hand side wall into the safe diagonally and plug it into the plug connection in the base. As soon as the side wall is plugged into the base, it can be stood upright on the left-hand side and screwed in (4mm Allen key) at the centre of the safe using the cylinder screw.

Caution: Only screw in lightly!

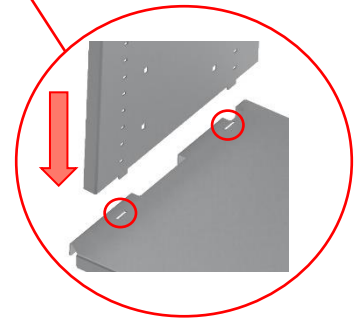
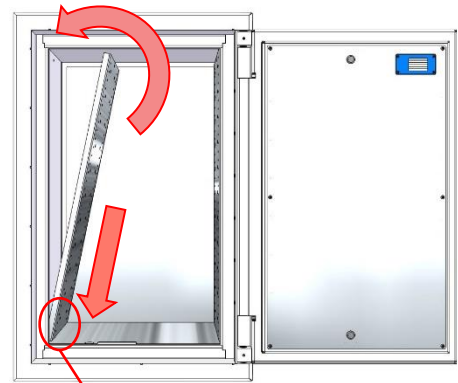

5. Guide the lid into the safe at an approx. 45° angle. Clip the tabs of the lid onto the top of the right-hand side wall and slowly pivot the lid upwards. Push the lid slightly to the right while doing this so that it does not align to the left-hand side wall when swivelled up. As soon as the left-hand tabs of the lid have been swivelled past the left-hand side wall, the lid can be pushed slightly to the left, and the tabs can be clipped onto the left-hand side wall.

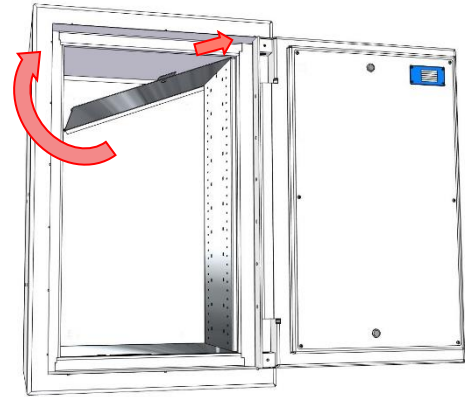

6. Once the lid is laid on both side walls, it can be pushed backwards against the rear wall. Pull the clamping plate forwards and secure over the countersunk screw (3mm Allen key) at the same time.

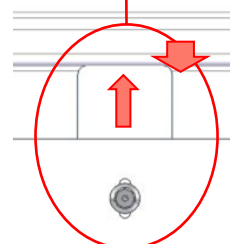
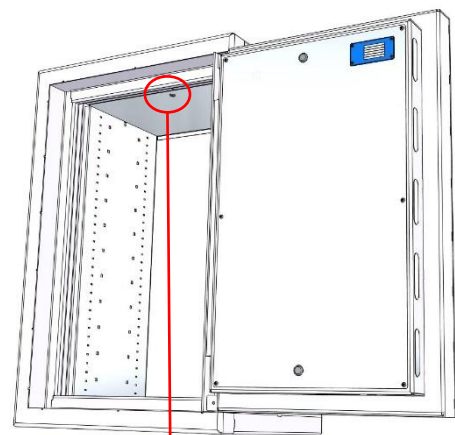

2.4. Cable entry / power connection

As standard, each safe is equipped with six cable entry openings. These are located on the right-hand and left-hand side, in the lower rear area of the safe. If none of the options listed below have been ordered, they are closed. The type plate for the electronic installation is located directly below these openings.

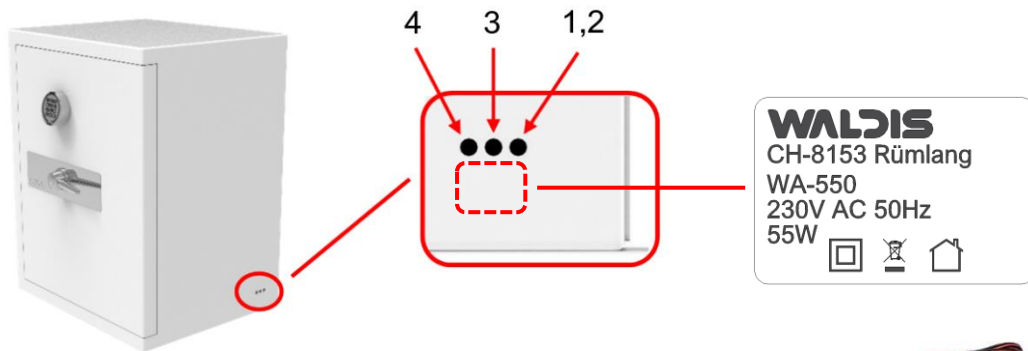

1. Mains connection Paxos Advance / Axessor
230V plug-in power supply with approx. 5m cable length.



2. Alarm preparation
Alarm control cable 12x 0.14mm² with approx. 5m cable length.



3. LED illumination
Connection for LED power supply 230V with hollow plug



up to size WA-1200
Dimensions (HxWxD) 57x32x76mm



from size WA-1450
Dimensions (HxWxD) 32x50x125mm

4. Power cable pull-in
The power cable for mains operation of watch winders is installed ready for operation and can be used immediately. The power cable is exclusively for supplying power to the USB hubs for powering the watch winders (chapter 2.6.).

The maximum output power of 40W is labeled on the T13 coupling inside the safe. This corresponds to the tested power and must not be exceeded!





In the event of cable damage or even a cable break, it must be replaced by WALDIS Tresore AG or an authorized specialist dealer!

WALDIS Tresore AG accepts no liability for personal injury or damage to property in the event of damage caused by faulty electronic installation in the safe, by unauthorized specialist personnel or by overloading the power supply!



To ensure that no cable breakage or other damage occurs to the cable or the power supply unit, a lateral distance of at least 5-10cm from the nearest object, furniture, wall, etc. must be planned.

2.5. USB-Hub

If watch winders with a mains connection are installed in the safe, these are supplied with power via a USB hub. Depending on the number of watch winders and the size of the safe, up to four USB hubs can be used.



The use of these USB hubs is intended exclusively for the watch winders!

WALDIS Tresore AG accepts no liability for personal injury or damage to property caused by third-party use of the USB ports.

3. Maintenance and care instructions

Your safe is essentially maintenance-free. However, we still recommend carrying out a lubricating and servicing interval as follows, depending on frequency of use but at least every 12 months:

- Lightly oil the hinges using penetrating oil (e.g. Brunox Turbo Spray).
- Open the door and extend the bolt using the handle, then grease lightly using a multi-purpose grease (e.g. Motorex 176 GP).
- The chrome-steel interior construction can be cleaned using a standard chrome-steel cleaner (e.g. Dr. Weigert neoblank spray).
- The varnished surfaces can be wiped down with a damp cloth.



WARNING: Do not clean with household chemical products!

Should any mechanical problems or electrical issues occur, please consult your trusted specialist dealer or contact WALDIS Tresore AG directly.

4. Exemption from liability

The above guarantee and the theft guarantee include a final provision with regard to the delivery of the item purchased. Any further liability is completely excluded. As for services by WALDIS that are to be arranged separately, such as transportation, packaging, insurance, assembly and installation, WALDIS' liability is limited to damage caused by gross negligence or deliberate intent (Art. 100, Para. 1 OR). The customer also recognises WALDIS' right to use external companies to fulfil the additional services listed. In this case, WALDIS' liability is limited to selecting and instructing the external companies with care (Art. 399, Para. 2 OR).

5. Guarantee against theft

WALDIS provides a guarantee against theft from the secure storage unit for safes starting from resistance level 2 to cover the duration stated in the order confirmation, as per European standard EN 1143-1. In particularly vulnerable locations, WALDIS may limit this guarantee or make it subject to additional measures, e.g. an alarm system. In these cases, the alarm system has to have been functional and activated at the time the theft took place and the alarm has to have been triggered and relayed. Otherwise, the theft guarantee terminates immediately.

The guarantee against theft means that, in the event of theft of the secure storage box anchored by WALDIS at that location, WALDIS is obliged to replace the secure storage box concerned, but not to cover damages resulting from the theft, or additional costs such as transportation and assembly of the new secure storage box, or disassembly or disposal of the old secure storage box. The customer is not entitled to any kind of compensation or replacement of the contents of the secure storage box. The guarantee against theft only applies to theft at the location where the secure storage box was positioned and anchored at least four times in accordance with the current instruction manual either by WALDIS or an authorised partner company. If the secure storage box is not positioned, anchored or moved by WALDIS or an authorised partner company, the theft guarantee terminates immediately.

The safe's warranty and certification terminate after attempted break-ins, fires and authorised interference with the structure.